

Gummikompensator

Art. 10-200 50

PN10

rubber expansion joint

Flansche geb. nach DIN EN 1092 PN10/16

Gehäuse: Stahl verzinkt

Innenteile: Gummi

Sitzdichtung: -

Temperaturbereich: 0°C - 110°C

flanges acc. to DIN EN 1092 PN10/16

Body: steel galvanized

Inner parts: rubber

Seat sealing: -

temperature range: 0°C - 110°C

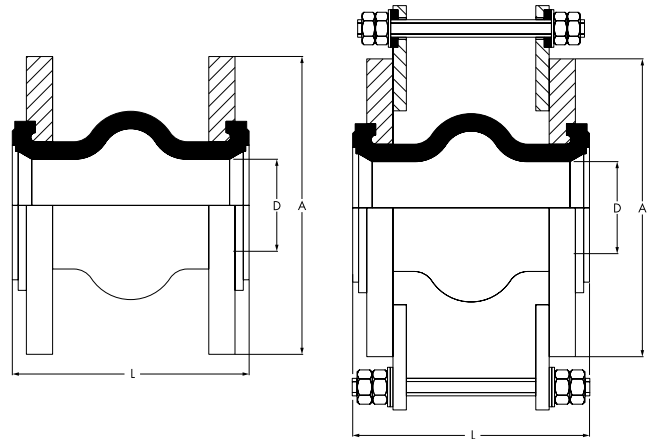

DN	L	axial +/-	øA	øk	n x ød						
20	130	30/30	105	75	4 x 14						
25	130	30/30	115	85	4 x 14						
32	130	30/30	140	100	4 x 18						
40	130	30/30	150	110	4 x 18						
50	130	30/30	165	125	4 x 18						
65	130	30/30	185	145	8 x 18						
80	130	30/30	200	160	8 x 18						
100	130	30/30	220	180	8 x 18						
125	130	30/30	250	210	8 x 18						
150	130	30/30	285	240	8 x 22						
200	130	30/30	340	295	8 x 22						
250	130	30/30	395	350	12 x 22						
300	130	30/30	445	400	12 x 22						
350	200	30/50	505	460	16 x 22						
400	200	30/50	565	515	16 x 26						

Folgende Bälge stehen zur Auswahl:

rot Aramid: Heizungsanlagen < 110°C

rot Nylon: Trink-und Warmwasser < 90°C

grün: chemische Anlagen

orange/gelb: Öle, Treibstoffe, Gase

schwarz/CR oder schwarz/EPDM:

Wasserleitungen (u.a. Seewasser)

bellows available:

red Aramid: heating plants < 110°C

red Nylon: drinking-/hot water < 90°C

green: chemical plants

orange/yellow: oils, fuels, gases

black/CR or black/EPDM: water pipes (e.g. seawater)

Alle Angaben sind unverbindlich und bleiben technischen Änderungen vorbehalten.
All data are not binding and subjected to change without notice.



Fritz Barthel Armaturen GmbH & Co. KG

Schnackenburgallee 16
22525 Hamburg (Germany)

Phone +49 (0) 40 398202-0
Fax +49 (0) 40 398202-77

E-Mail post@barthel-armaturen.de
Internet www.barthel-armaturen.de

06.2010