

Wartungseinheit, 3-teilig

Art. 08-045

PN16/10

maintenance unit for compressed air

bestehend aus Filter
 Druckregler mit Manometer
 Nebelöler

Form: Durchgangsform
Anschluß: Innengewinde nach ISO 228/1
Gehäuse: Zinkdruckguss
Innenteile: Sinterbronze/PC
Sitzdichtung: NBR

*consist. of filter, pressure regulator
 with pressure gauge
 oil mist blower*

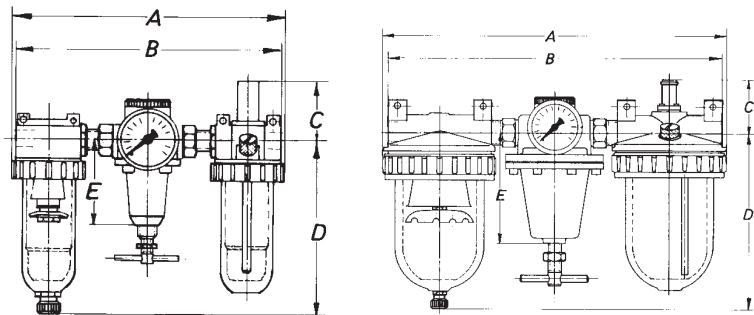

Form: straight type

Connection: female thread acc. to ISO 228/1 G1/8 - G1/2

G3/4 - G11/2

Body: zinc diecasting

Inner parts: sintered bronze/PC

Seat sealing: NBR

G	A	B	C	D	E	kg									
1/8	196	197	51	135	67	0,4									
1/4	196	197	51	135	67	0,7									
3/8	196	197	51	135	67	1,4									
1/2	281	274	55	172	85	2,6									
3/4	332	332	69	176	90	3,5									
1	332	320	69	176	90	4,0									
1 1/4	426	382	58	206	130	4,8									
1 1/2	426	370	58	206	130	6,1									
2	332	320	69	176	-	8,1									

Alle Angaben sind unverbindlich und bleiben technischen Änderungen vorbehalten.
 All data are not binding and subjected to change without notice.



Fritz Barthel Armaturen GmbH & Co. KG

Schnackenburgallee 16
 22525 Hamburg (Germany)

Phone +49 (0) 40 398202-0
 Fax +49 (0) 40 398202-77

E-Mail post@barthel-armaturen.de
 Internet www.barthel-armaturen.de

02.2017