

Flansch-Kugelhahn

Art. 03-411

PN16

flange ball valve

voller Durchgang

Baulänge nach DIN 3202-F4

Flansch gebohrt nach DIN PN16

Anschluß:

DIN DVGW-Zulassung

Gehäuse: Sphäroguss

Innenteile: Messing

Sitzdichtung: PTFE

Temperaturbereich: -10°C - 90°C

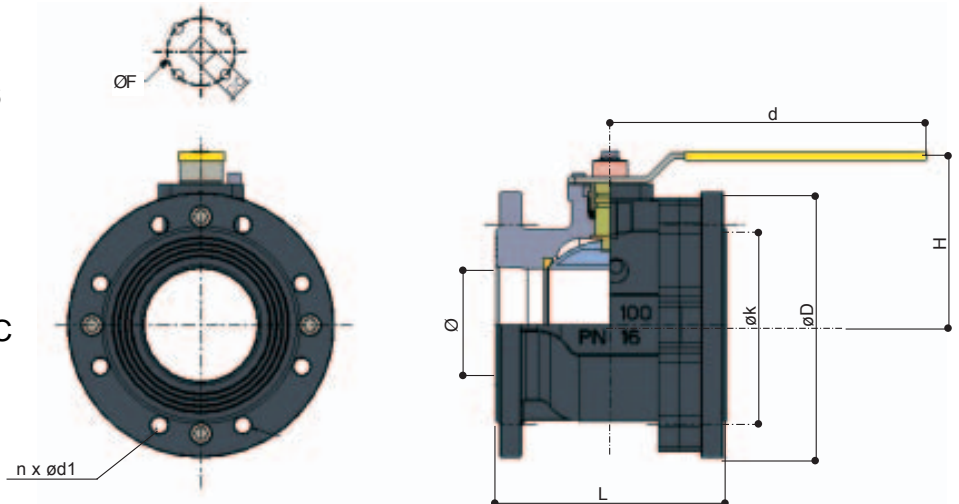

full bore

length acc. to DIN3202-F4

flanges acc. to DIN PN16

Connection:

DIN DVGW-approval

Body: nodular cast iron

Inner parts: brass

Seat sealing: PTFE

temperature range: -10°C - 90°C

DN (ø)	L	H	d	øD	øk	n x ød1	øF	ISO	kg		
20	120	73	200	105	75	4 x 14	42	F04	2,7		
25	125	77	200	115	85	4 x 14	42	F04	3,6		
32	130	82	200	140	100	4 x 18	42	F04	4,8		
40	140	92	240	150	110	4 x 18	50	F05	6,2		
50	150	99	240	165	125	4 x 18	50	F05	9,0		
65	170	121	260	185	145	4 x 18	70	F07	12,2		
80	180	130	260	200	160	8 x 18	70	F07	15,5		
100	190	144	260	220	180	8 x 18	70	F07	20,0		
125	200	185	450	250	210	8 x 18	102	F10	28,0		
150	210	204	450	285	240	8 x 22	102	F10	38,5		

Alle Angaben sind unverbindlich und bleiben technischen Änderungen vorbehalten.
All data are not binding and subjected to change without notice.



Fritz Barthel Armaturen GmbH & Co. KG

Schnackenburgallee 16
22525 Hamburg (Germany)

Phone +49 (0) 40 398202-0
Fax +49 (0) 40 398202-77

E-Mail post@barthel-armaturen.de
Internet www.barthel-armaturen.de

07.2010