

Flansch-Keil-Flachschieber

Art. 02-021

PN10/16

flange wedge gate valve

DIN 3352-2

Flansche geb. nach DIN EN 1092 PN10/16

Gehäuse: Bronze G-CuSn10

Innenteile: Bronze CuSn6

Sitzdichtung: metallisch

Temperaturbereich: -10°C - 180°C

flanges acc. to DIN EN 1092 PN10/16

Body: zincfree bronze

Inner parts: bronze

Seat sealing: metallic

temperature range: -10°C - 180°C

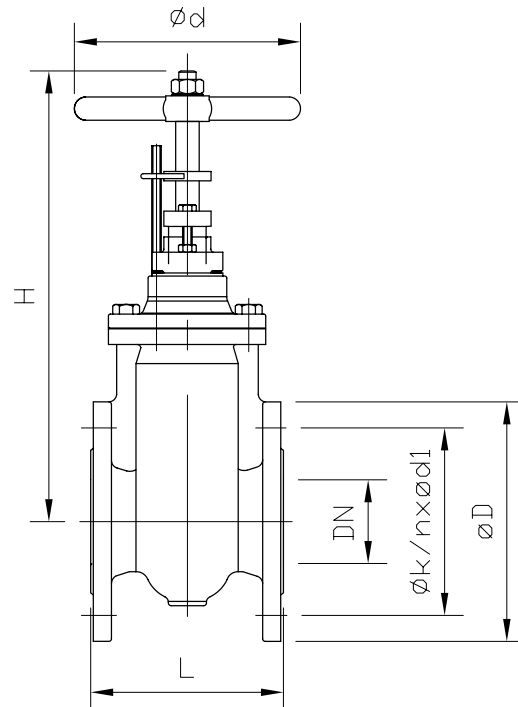

DN	L	H	ϕd	ϕD	ϕk	n x $\phi d1$	kg				
25	125	170	120	115	85	4 x 14	5,5				
32	130	185	120	140	100	4 x 18	7,8				
40	140	240	120	150	110	4 x 18	10,5				
50	150	255	120	165	125	4 x 18	12,0				
65	170	295	160	185	145	4 x 18	17,0				
80	180	315	160	200	160	8 x 18	21,0				
100	190	345	160	220	180	8 x 22	28,0				
125	200	400	200	250	210	8 x 22	36,0				
150	210	430	200	285	240	8 x 22	46,0				
200	230	530	250	340	295	8 x 22	62,0				
250	250	635	250	395	350	12 x 22	96,0				
300	270	725	250	445	400	12 x 22	140,0				

Alle Angaben sind unverbindlich und bleiben technischen Änderungen vorbehalten.
All data are not binding and subjected to change without notice.



Fritz Barthel Armaturen GmbH & Co. KG

Schnackenburgallee 16
22525 Hamburg (Germany)

Phone +49 (0) 40 398202-0
Fax +49 (0) 40 398202-77

E-Mail post@barthel-armaturen.de
Internet www.barthel-armaturen.de

06.2010