

Flansch-Druckminderventil

Art. 05-061

PN40

flange pressure reducing valve

Flansche nach DIN PN40

Gehäuse: Stahlguss
 Innenteile: Edelstahl
 Sitzdichtung: metallisch
 Temperaturbereich: -10°C - 300°C

flanges acc. to DIN PN40

Body: cast steel
 Inner parts: stainless steel
 Seat sealing: metallisch
 temperature range: -10°C - 300°C

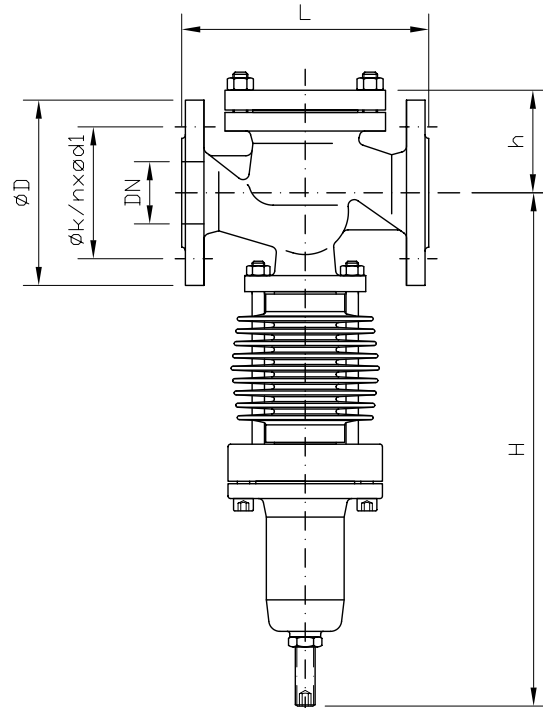

DN	L	h	H	øD	øk	n x ød1	kg				
15	130	90	435	95	65	4 x 14	12,0				
20	150	90	435	105	75	4 x 14	12,0				
25	160	90	435	115	85	4 x 14	13,0				
32	180	120	455	140	100	4 x 18	16,0				
40	200	120	455	150	110	4 x 18	18,0				
50	230	130	605	165	125	4 x 18	37,5				
65	290	155	635	185	145	8 x 18	43,0				
80	310	180	800	200	160	8 x 18	58,0				
100	350	180	825	235	190	8 x 22	77,0				

Alle Angaben sind unverbindlich und bleiben technischen Änderungen vorbehalten.
 All data are not binding and subjected to change without notice.

