

Flansch-Keil-Flachschieber

Art. 02-028

PN16/10

flange wedge gate valve

DIN 3352 (86703)

Flansche geb. nach DIN EN 1092 PN10/16

Gehäuse: Stahlguss
 Innenteile: Niro
 Sitzdichtung: metallisch
 Temperaturbereich: -10°C - 120°C

flanges acc. to DIN EN 1092 PN10/16

Body: cast steel
 Inner parts: stainless steel AISI316
 Seat sealing: metallic
 temperature range: -10°C - 120°C

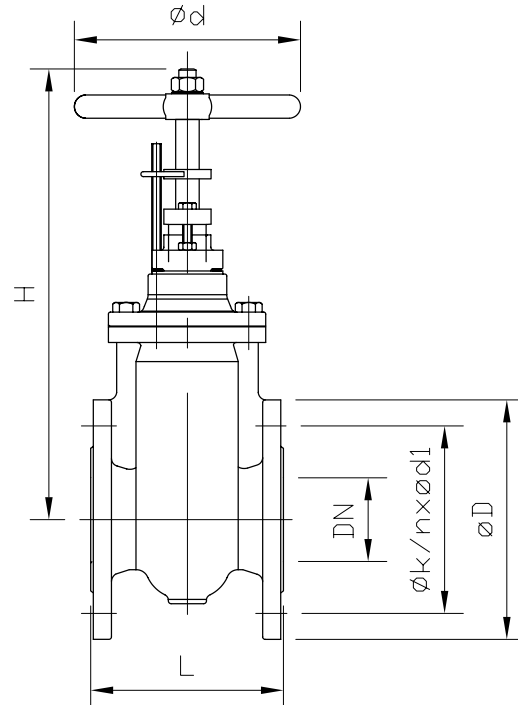

DN	L	H	ød	øD	øk	n x ød1	kg				
40	140	265	140	150	110	4 x 18	15				
50	150	270	140	165	125	4 x 18	17				
65	170	295	160	185	145	4 x 18	20				
80	180	325	160	200	160	8 x 18	27				
100	190	365	200	220	180	8 x 18	34				
125	200	440	200	250	210	8 x 18	50				
150	210	490	200	285	240	8 x 22	60				
200	230	610	250	340	295	8 x 22	100				
250	250	730	315	395	350	12 x 22	165				
300	270	870	315	445	400	12 x 22	220				
350	290	950	400	505	460	16 x 22	290				
400	310	1045	400	565	515	16 x 26	370				
500	350	1250	500	670	620	20 x 26	580				
600	390	1475	630	780	725	20 x 30	715				

Weitere Ausführungen:
 - mit Entwässerung, Feststellvorrichtung,
 Kettenhandrad

options:
 - with drain plug, locking device or
 chainwheel

Alle Angaben sind unverbindlich und bleiben technischen Änderungen vorbehalten.
 All data are not binding and subjected to change without notice.



Fritz Barthel Armaturen GmbH & Co. KG

Schnackenburgallee 16
 22525 Hamburg (Germany)

Phone +49 (0) 40 398202-0
 Fax +49 (0) 40 398202-77

E-Mail post@barthel-armaturen.de
 Internet www.barthel-armaturen.de

06.2010